

# ***ETON***

## ***Modell 7.4***

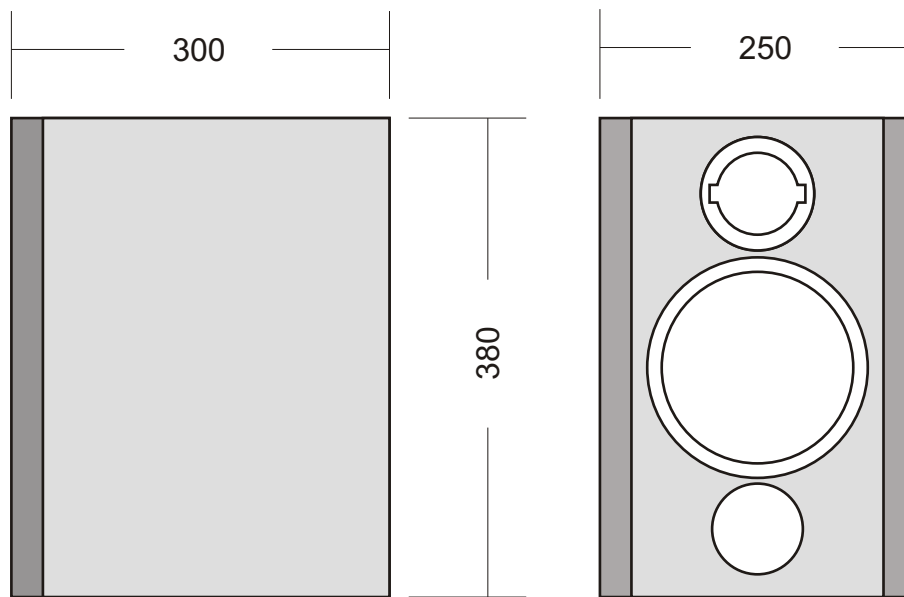

BODEN

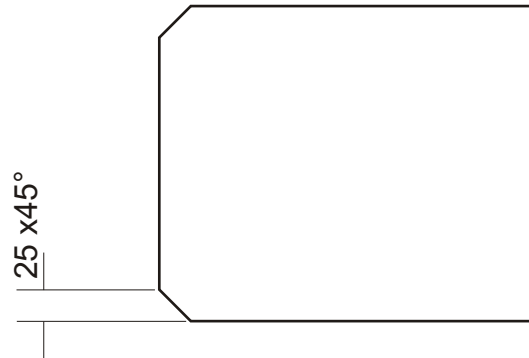

Schnitt A-A

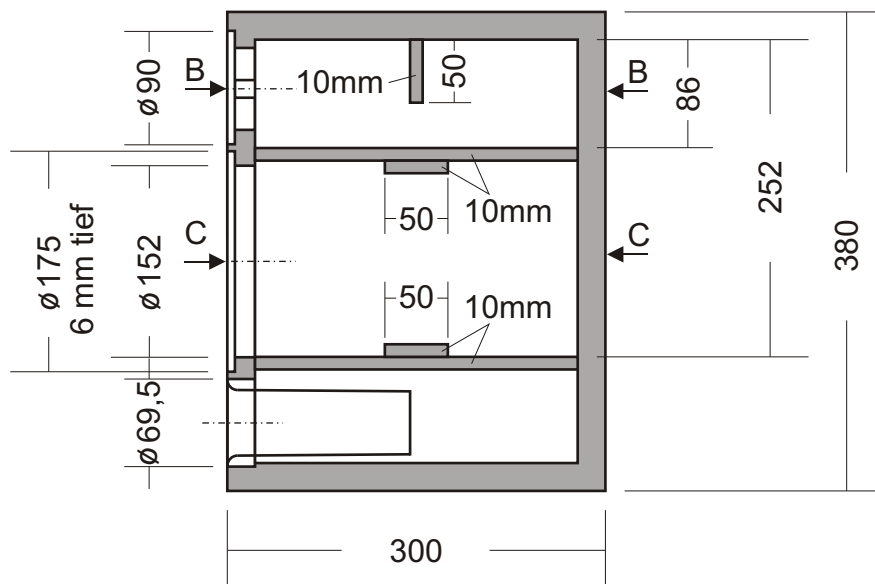

Bassreflexrohr  $\varnothing$  50 / 140 lang

**Eton Modell 7.4**  
Material MDF 22 mm  
MDF 10 mm  
Maßstab 1 : 6

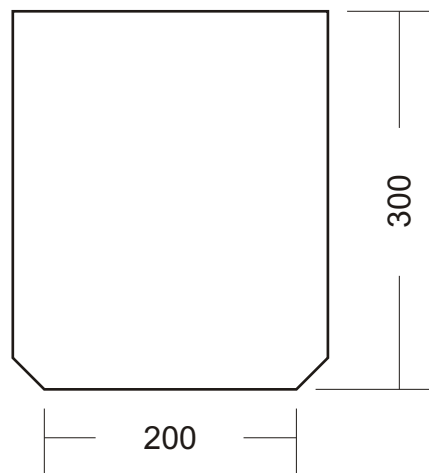
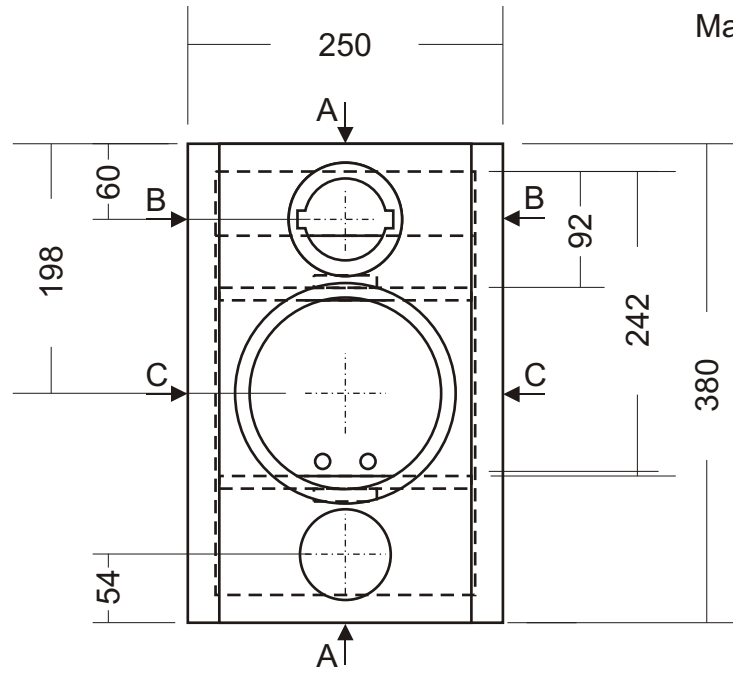

Detail Hochtöner

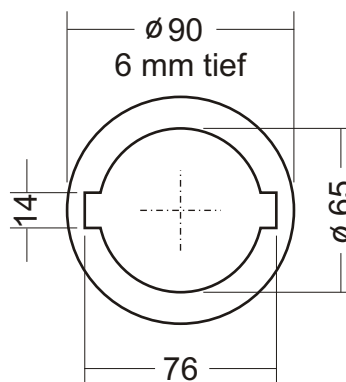

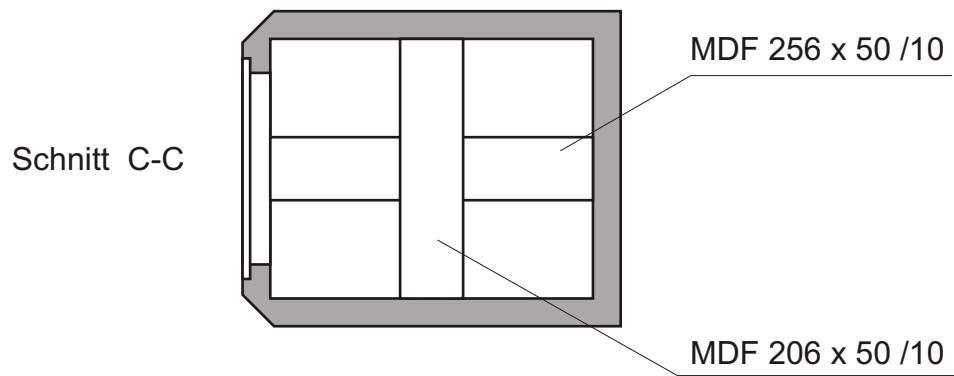
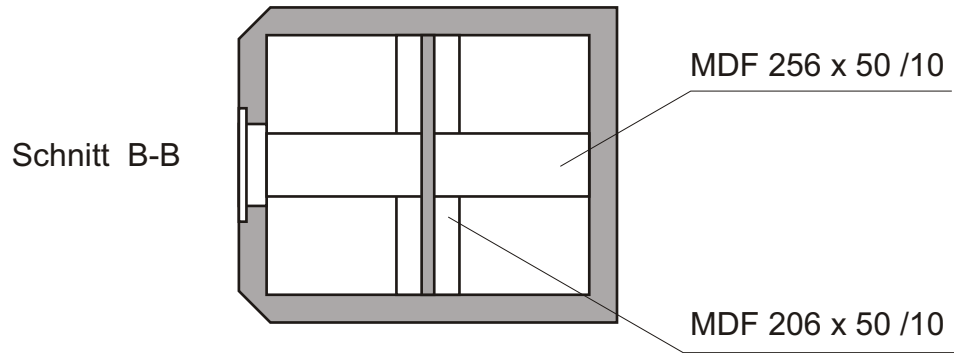

**Eton Modell 7.4**  
Material MDF 22 mm  
MDF 10 mm  
Maßstab 1 : 6

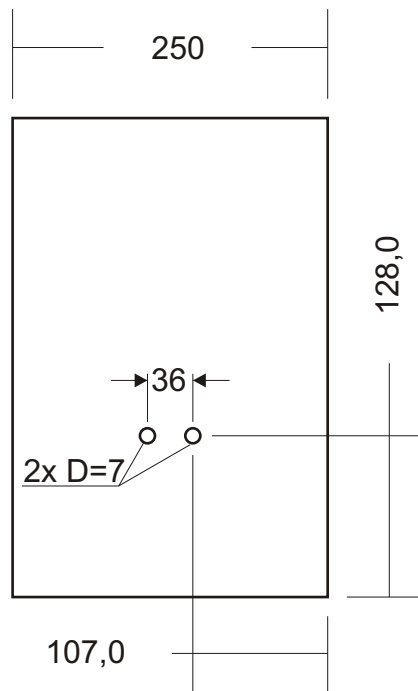

Damping = Polyester fleece mat

